

 **Dometic**
SERVICE

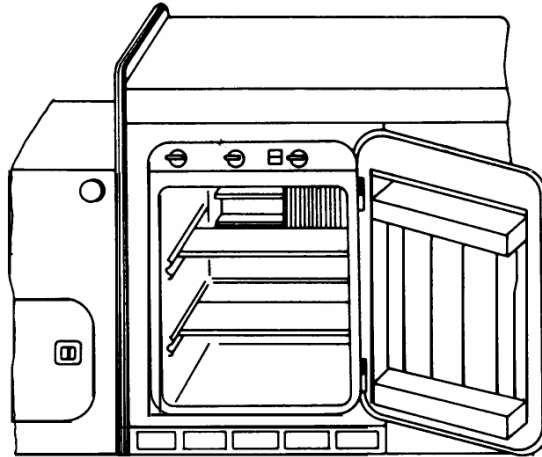

SERVICE MANUAL

REFRIGERATOR

RM182B

When ordering spare parts always state:

MODEL. QUANTITY * PART NUMBER * DESCRIPTION For electric details

also:

VOLTAGE -WATTAGE

Edition **2**

August 1982
DSC #651

TABLE OF CONTENTS

A. Installation Instructions	Page 2
B. Instructions For Use RM182B	Page 3
General Instructions	Page 4
Sealed Combustion Unit	Page 4
Ventilator (improved cooling performance)	Page 4
Fuse - 12 Volt Circuit	Page 4
Steps To Take When The refrigerator Has Not Been Used For A Long Period	Page 4
Pilot Outage	Page 4
Periodic Maintenance	Page 4
C. Removal And Installation Of Refrigerator	Page 5
D. Component Replacement	Page 6
Replacing The Electric Heating Element	Page 6
Replacing Voltage Selection Switch	Page 6
Replacing Gas Shut-Off Valve (Gas-Cock)	Page 6
Replacing Thermostat And Flame Failure Safety Device (Safety Valve)	Page 6 & 7
Replacing Thermo-current Adapter	Page 7
Replacing Thermocouple	Page 7
Replacing Spark Ignitor With Cable	Page 7
Replacing Burner Jet	Page 8
Cooling Unit Replacement	Page 8
Removing The Air Pump And Replacing The Piston (Joint Ring)	Page 9
E. Wiring Diagram	Page 9
F. Troubleshooting The Refrigerator- L.P. Gas	Page 10
G. Troubleshooting The Refrigerator - Electric	Page 11
H. Figures 1 through 15 RM182 B	Page 12 -

INSTALLATION INSTRUCTIONS

The design of this refrigerator has been certified and approved by the American Gas Association and the Canadian GAS Association for Recreational Vehicles.

This certification is dependent, however upon proper installation'-and the use of the venting components as shown in these instructions. Installation

The installation of the refrigerator must comply with local codes or in the absence of local codes the following American National Standards and Canadian Standards are applicable

In the USA:

ANSI z 223.1.- 1978 National Fuel Gas Code

ANSI c 1 1978 National Electric Code

In Canada:

CSA Std. Z 240.4. - *Gas Equipped Recreational Vehicles and Mobile Housing

*Note: Will be replaced by CSA Stds. Z 240.4.1 and Z240.4.2. when available.

CSA Std. Z 240.6.1. - Electrical Requirement for Mobile Housing

CSA Std. Z 240.6.2. - Electrical Requirement for Recreational Vehicles

B. INSTRUCTIONS FOR USE RM182B

The Controls : Controls are located at the top of the refrigerator.

1. Control Panel : Fig. 1 Page 1

"A" - Air Pump and Piezo Lighter

"B" - Safety Valve

"C" - Thermostat for Gas and 120 Volt Operation (12 volt has no thermostat, the unit runs continuously)

"D" - Voltage Selector Switch

"E" - Gas Shut-Off Valve

"F" - Flame Pilot Sight Peep

2. Gas Operation - Lighting the Burner

1. Place Voltage Switch "D" (Fig. 1) on position  then place Gas Valve "E" (Fig. 1) to position 1

2. Turn thermostat "C" (Fig. 1) to maximum

3. Depress button "B" (Fig. 1) for 20 seconds to let gas flow to burner

4. Release button "B" and pump knob "A" (Fig. 1) 20 times DO NOT pump until click is heard, stop short of this position.

5. Once again, press button "B" (Fig. 1) and hold, simultaneously pump knob "A" (Fig. 1) several times until noticeable click is heard (this is Piezo Lighter).

6. When burner is lit, hold button "B" (Fig. 1) for at least 10 seconds

7. Flame may be observed through pilot sight peep "F" (Fig. 1) and ice, tray should show signs of cold after two hours

3. Electrical Operation

1. Place Gas Valve "E" (Fig. 1) to position 0

2. Place Voltage Selector Switch "D" (Fig. 1) to the appropriate voltage.

NOTE: The 12 volt circuit is not thermostatically controlled, Because of an inserted relay, the 12 Volt operation is only possible if the car ignition is switched on.

4. Temperature Control

With the thermostat knob "C" (Fig. 1) set at the middle position, the cabinet will automatically maintain a suitable temperature for ordinary food storage. Usually, no further adjustment will be necessary, but in hot weather, or when more cooling is required, the knob "C" (Fig. 1) must be turned to a higher position.

If less cooling is required, the knob should be turned to a lower position.

If knob "C" (Fig. 1) is turned completely to the left, the 120 Volt circuit is switched off. During gas operation the same position corresponds to Minimum Cooling.

General Instructions

Sealed Combustion Unit

The sealed combustion unit is made up of the burner, a fresh air intake and exhaust pipes, and a vent/air-intake assembly in the wall.

The burner unit is completely sealed off from the interior of the van by means of the two special inlet and outlet pipes. In the vent /air-intake assembly, fresh air is drawn in one pipe and combusted gases are safely vented to the outside through the other pipe.

Ventilator (Cooling Fan)

In order to improve the cooling performance under the difficult built-in situation and high ambient temperatures, a 0,6 W ventilator is switched on automatically when the temperature around the condenser fins (behind the refrigerator) reaches 140 F and switched off at 124 F.

NOTE:

The ventilator is connected to the 12 V-circuit in such a manner that it is also operational during the 120 V and gas operations.

Fuse

For 12 V use the refrigerator is protected by a fuse installed in the general electrical circuit of the vehicle. If the fuse blows out, trace the cause and correct it before fitting a new low amp. fuse.

Steps To Take When The Refrigerator Has Not Been Used For A Long Period

If there has been a heavy rain, or the vehicle has been through a car wash, water may have collected in the burner housing. This must be removed before the gas is lit. For this, the sealing plug underneath the front of the refrigerator on the left is unscrewed from the drainage tube and the water is allowed to escape. The sealing plug must then be carefully refitted since a good seal is essential for the proper function of the combustion system. Check that the windscreen of the outside wall of the van is clean and remove any dirt that is present.

Pilot Outage

It has been determined that this problem can be caused by a poor seal between the slide for ventilation housing "E" (Fig.2) and the side wall of the vehicle.

When properly sealed, this plate acts as a baffle to protect the exhaust outlet tube from direct air flow. If this seal is not complete, air will be allowed to flow between the plate and the side wall of the vehicle directly into the exhaust outlet tube.

This problem can be caused by failure to tighten the mount "D" (Fig. 2) screws properly, a bad gasket "F" (Fig.2) or a warped locating plate "E" (Fig. 2).

Periodic Maintenance

Once or twice a year, depending on use, it is necessary to clean and adjust the burner assembly.

The burner is fitted with a # 24 jet, which is suitable for use on Propane or Butane gas at a supply pressure of 11 inches water column pressure. The orifice in the jet is very small and must never be cleaned by means of a pin or a similar instrument for this will damage the orifice. Should, for some reason, the jet require cleaning, it should be washed in alcohol and blown dry with air.

The entire gas installation should be checked for leaks. Test all pipe connections with soapy water, not with an open flame.

C. REMOVAL AND INSTALLATION OF REFRIGERATOR

Removal

1. Disconnect electrical supply. And make sure the gas supply is shut off at its source.
 2. Remove the vent /air-intake assembly on the van wall outside .
 - a. Unscrew three self-tapping screws (A, Fig.2) of the windscreen (B, Fig.2) then remove windscreen and separating plate (C, Fig. 2).
 - b. Unscrew four screws (D, Fig.2) of the fixing plate (E, Fig. 2) and remove fixing plate and gasket (F, Fig. 2) from the caravan wall (G, Fig. 2) to the vent casing (H, Fig. 2).
 3. Open and remove all three doors of the kitchen cabinet (Fig.3). Pull out drawer. Dismantle and remove shelves. Then lift door from hinge posts (Fig.3).
 4. Remove three protective caps (A, Fig.4) from the refrigerator frame (B, Fig.4) and unscrew the three screws that are behind the caps. Then on each side through the doors, unscrew two phillips screws (C, Fig.4) from the walls of the refrigerator.
 5. Carefully pull refrigerator frame forward in the lower right (Fig. 5, arrow A) then pull out the left groove according to arrow (B, Fig.5) toward the right.
 6. Remove 120 V connection plug (A, Fig.6) from the socket, pull out 12 V plug connection (B, Fig.6). Unscrew threaded union of the gas-connection line (C, Fig.6) of the refrigerator.
 7. Unscrew ventilation grill (A, Fig. 7) by removing two screws (B, Fig. 7) and then remove refrigerator by pulling forward.
- Installation

The installation is carried out in the reverse sequence to that described for the removal of the refrigerator.

IMPORTANT:

After installation, check gas system for leaks, with soapy water. NEVER USE A MATCH

D. COMPONENT REPLACEMENT RM182B

NOTE:

For the removal of gas and electrical components and of the refrigerator cooling unit, the refrigerator must be removed from the kitchen cabinet (see chapter C) .

1. Replacing the electric heater

1. Squeeze the heater insulation in direction of arrow (A, Fig. 8) until it clicks open. Pull open the insulation in direction of arrow (B, Fig. 8) and remove it .
2. Unscrew fixing screw (C, Fig. 8) of the heater and remove the heater from its pocket by pulling straight up.
3. Unscrew the two screws of the cover (F, Fig. 9) exposing the terminal block.
4. Unscrew the heater cable at the terminal block and remove heater with cable.
5. To replace heater, reverse the procedure.

NOTE:

The heater has a groove (D, Fig. 8) at the bottom, into which the fixing screw fits. Place the new heater inside the heater tube so that the groove is in the correct position for the fixing screw. The bottom of the heater should be level with the bottom of the heater tube.

2. Replacing the voltage selection switch (D, Fig. 9)

1. Remove plug-connections of the voltage selection switch.
2. Press in the four fixing legs on the switch and at the same time press out the switch from the control panel.
3. To replace switch, reverse the procedure.

3. Replacing --the gas-cock G Fig. 9)

1. Unscrew union nut (H, Fig. 9) and union nut (I, Fig. 9)
2. Unscrew support bracket (J, Fig 9) for gas-cock (2 screws) . 3. To replace gas-cock, reverse the procedure.

4. Replacing the thermostat and flame failure safety device (Safety Valve)

1. Remove ice-tray support (A, Fig. 10) from evaporator by withdrawing in a forward direction.

CAUTION: Only take hold of it at the left side (indicated by the arrow). Now pull the capillary tube of the thermostat off.

2. Bend straight the capillary tube from the rear of the cabinet.
3. Unscrew union nut (A, fig. 11) from gas-cock (B, fig. 11). (Use a second fork-spanner to hold counterpart the gas-cock).

4. Pull off thermostat knob (C, Fig.11) and knob (D, Fig.11) of safety device (E, Fig. 11).
5. Unscrew union nut (F, Fig.11) of gas-pipe (G, Fig.11) from flame failure safety device (E, Fig. 11).
6. Remove three cable plug-connections from thermostat (H, Fig.11).
7. Unscrew thermo-coupling (I, Fig.11) from thermo-current adapter (J, Fig.11).
8. Unscrew thermostat (H, Fig.11) from support bracket (K, Fig.11) (2 screws).
9. Unscrew two clips (L, Fig.11) from capillary tube (M, Fig.11).
10. Remove gas-equipment from cabinet and dismantle.
11. Dismantling of thermostat (H, Fig.11) : Unscrew flame failure safety device (E, Fig.11) with thermo-current adapter (J, Fig.11) and the connection (N, Fig.11) from thermostat.
12. Dismantling of the flame failure safety device (E, Fig.11) : Unscrew flame failure safety device from thermostat (H, Fig.11). Then unscrew thermo current adapter (J, Fig.11) from the flame failure safety device.
13. For reassembly, proceed in the reverse sequence of dismantling.

CAUTION: Coat threaded unions at the connection/thermostat and thermostat/flame failure safety device with Loctite 572 to ensure good sealing. Be careful not to get any Loctite inside any parts.

5. Replacing the thermo-current adapter (J, Fig. 11).

1. Unscrew thermo-coupling (I, Fig.11) from thermo-current adapter.
2. Unscrew thermo-current adapter from flame failure safety device (E, Fig.11) and replace by new unit.

6. Replacing the thermocouple (I, Fig. 11)

1. Unscrew thermo-coupling from thermo-current adapter (J, Fig. 11).
2. Unscrew clip (O, Fig.11) for gas-pipe (G, Fig.11) and thermocouple.
3. Unscrew the three screws of the mounting plate (A, Fig.12) from the bottom part of gas-burner. Take off spark ignitor (B, Fig.12), mounting plate with thermocouple (I, Fig.12) and gasket (C, Fig.12).
4. Unscrew lock-nut (D, Fig.12) of the thermocouple
5. Bend new thermocoupling (I, Fig. 11+12) to shape of old one. For reassembly, proceed in the reverse sequence of dismantling.

IMPORTANT: The gasket (C, Fig.12) between the lower part of the burner and the mounting plate must be replaced by a new one and carefully positioned to ensure that the burner is properly sealed.

7. Replacement of spark ignitor with cable (B, Fig. 12)

1. Remove ignition cable (P, Fig.11) from piezo ignitor (Q, Fig.11).
2. Unscrew the one screw (A3, Fig.12) from the spark ignitor, withdraw spark ignitor and replace it by a new one. Reassemble in the reverse order.

8. Replacing the burner-jet (E Fig. 1 2)

1. Unscrew union nut (F, Fig. 12) of gas pipe by using a 10 mm fork-spanner and a second one (14 mm) to hold counterpart the jet.
2. Unscrew burner jet from the bottom part of gas-burner. 3. Screw in the new burner jet, refit gas pipe.

IMPORTANT: The gasket (G, Fig.12) between the lower part of the burner and the burner-jet must be replaced by a new one and carefully positioned to ensure that the burner is properly sealed.

9. Cooling unit replacement.

1. Unscrew thermo-coupling (I, Fig.11) from thermo-current adapter (J, Fig.11).
2. Unscrew clip (O, Fig.11) for gas-pipe (G, Fig.11) and thermocouple.
3. Remove the three connections (A, Fig. 13/R, Fig.11), unscrew support bracket (B, Fig. 13) of the ventilator.
4. Unscrew thermostat (S, Fig. 11) from condenser fins and remove plug-connection of grounding cable (T, Fig. 11) above the condenser fins.
5. Squeeze the heater insulation in direction of arrow (A, Fig.8) until it clicks open. Pull open the insulation in direction of arrow (B, Fig. 8) and remove it.
6. Unscrew fixing screw (C, Fig.8) of the heater and remove the heater from its pocket by pulling straight up.
7. Unscrew union nut (A, Fig. 14) of flexible exhaust pipe (B, Fig. 14) using a pipe wrench, remove flexible pipe and gasket from gas heating-pipe (C, Fig.14).
8. Unscrew union nut (U, Fig.11) from air feed-pipe.
9. Unscrew six screws (A, Fig.15) from the bottom part of gas burner and two screws from support bracket (B, Fig.15) of the drainage tube (C, Fig. 15).
10. Take off bottom part of burner with thermocouple, gas pipe and spark ignitor with cable from upper part of burner (D, Fig.15) by withdrawing to the right side .
11. Unscrew upper part of gas burner (D, Fig.15) with air inlet pipe (E, Fig.15) from the gas heating pipe (F, Fig.15) (2 screws G, Fig. 15).
12. Unscrew locking plate from pilot sight peep (H, Fig.15).
13. Unscrew eight screws (I, Fig. 15) from the cooling unit attachment panel and take cooling unit out of the cabinet.
14. For the installation of the cooling unit, proceed in the reverse sequence.

CAUTION: The location of the thermostat capillary tube should be noted at this time for relocation later on. The tubes must be placed in the correct position otherwise, improper performance will result..

IMPORTANT : The gasket (H, Fig.12) between the lower and upper part of the burner must be replaced by a new one and carefully positioned to ensure that the burner is properly sealed. Also the gasket (I, Fig.12) between the upper part of the burner and the gas heating pipe should be replaced too.

10. Removing the air pump and replacing the piston.

1. Unscrew knob (A, Fig.9) of air pump (K, Fig.9) from the shaft (L, Fig.9).
2. Unscrew air pump (4 screws / M, Fig. 9).
3. Unscrew cover of air-pump (2 screws / N, Fig. 9).
4. Withdraw shaft, force out retaining disc from the groove, pull off large disc and change joint ring.
5. Reassemble in the reverse order.

CAUTION: After all repairs to the gas equipment, the entire gas system must be checked for leaks with soapy solution. **NEVER USE A MATCH**

E. WIRING DIAGRAM

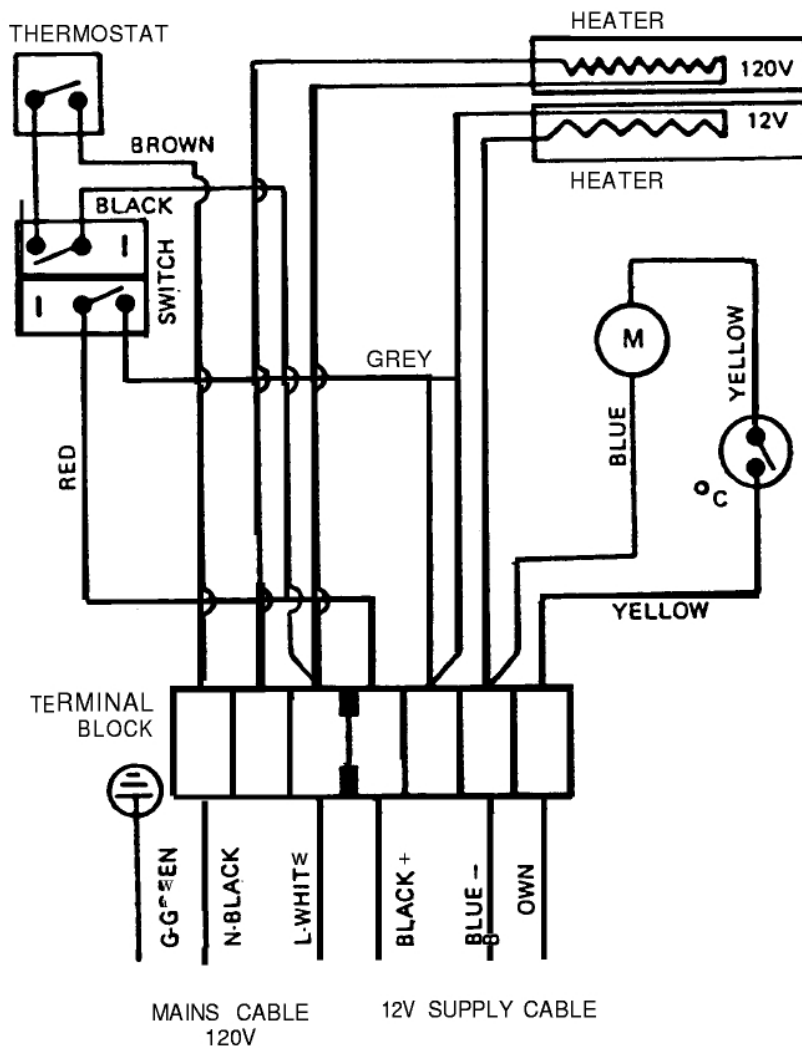

G. TROUBLESHOOTING THE REFRIGERATOR - ELECTRIC

SYMPTOM					CAUSE
Refrigerator too cold	Refrigerator not cold enough	No refrigeration	Frost forms rapidly	Odor inside cabinet	
					NOTE: It will be noted in this guide that several causes can be responsible for one effect. The real cause or causes should be determined by the process of elimination, investigating each possible cause, starting at the top of the guide and proceeding to the bottom.
	✓	✓			Inadequate ventilation
	✓	✓			Refrigerator not level
	✓	✓			Defective heater, wrong voltage or type
	✓	✓			Voltage not constant
		✓			Electric connections loose
	✓	✓			Heater not inserted correctly in its pocket
	✓	✓			Improper food storage
✓	✓	✓			Thermostat incorrectly used
			✓		Improper storage of liquid and moist foods
	✓	✓	✓		Leaky cabinet seals
				✓	Infrequent cleaning of food compartment
				✓	Refrigerator shut off with closed door
				✓	Unwrapped odorous food
✓			✓		Incomplete contact of the thermostat capillary tube
	✓	✓			Thermostat charge lost
	✓	✓			Refrigerator unit failure
✓					Ambient temperature too low
		✓			12 Volt relay faulty
	✓				Ambient temperature too high

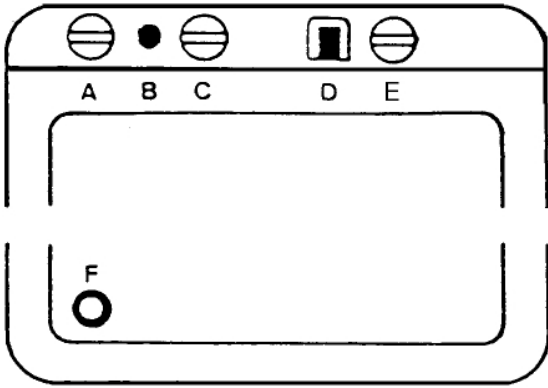

Fig. 1

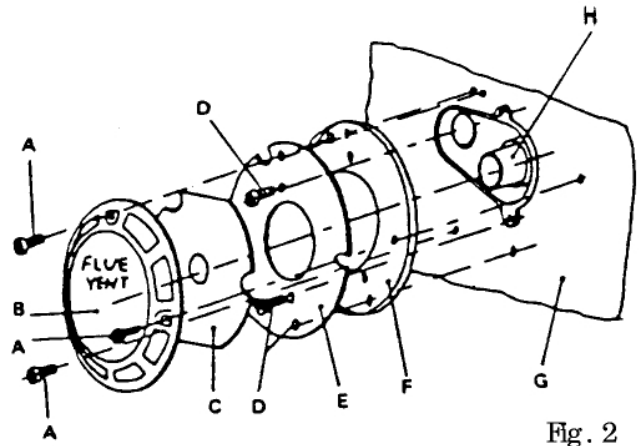

Fig. 2

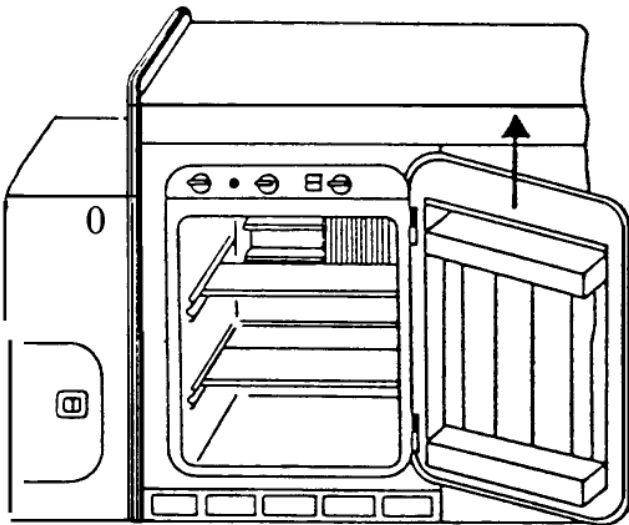

Fig. 3

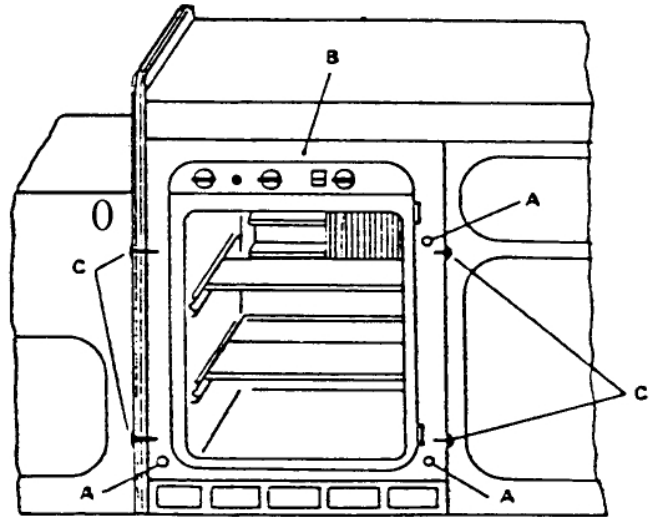

Fig. 4

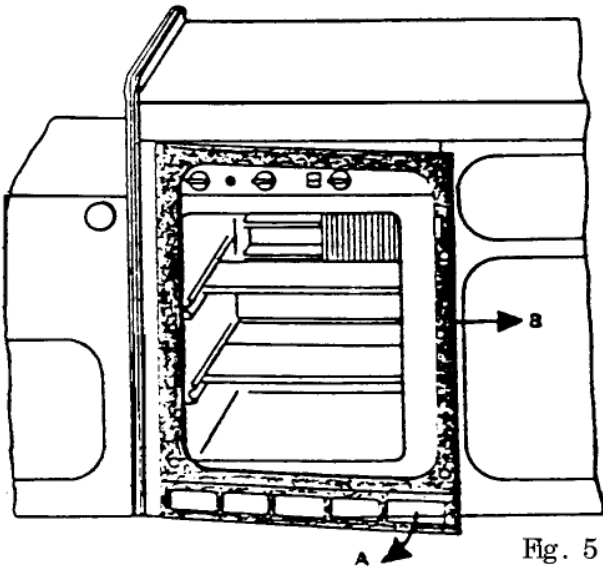

Fig. 5

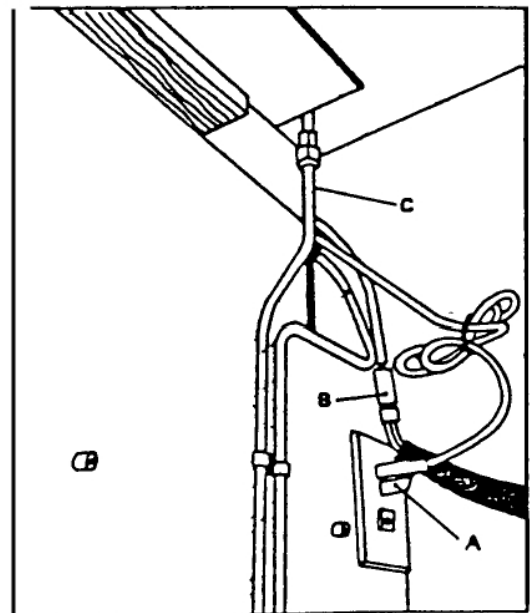

Fig. 6

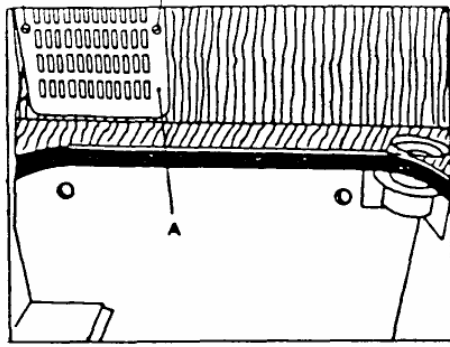

Fig. 7

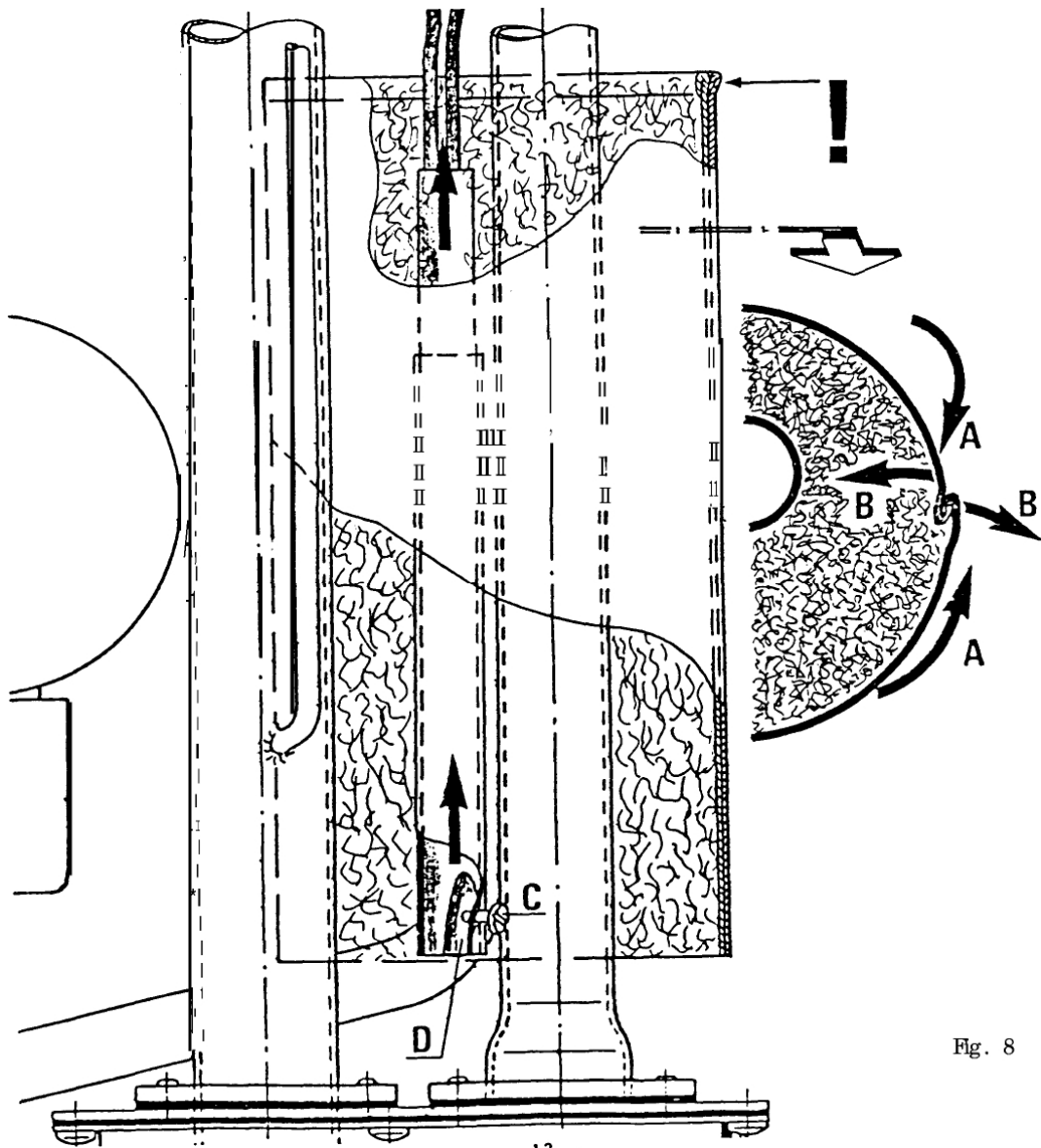

Fig. 8

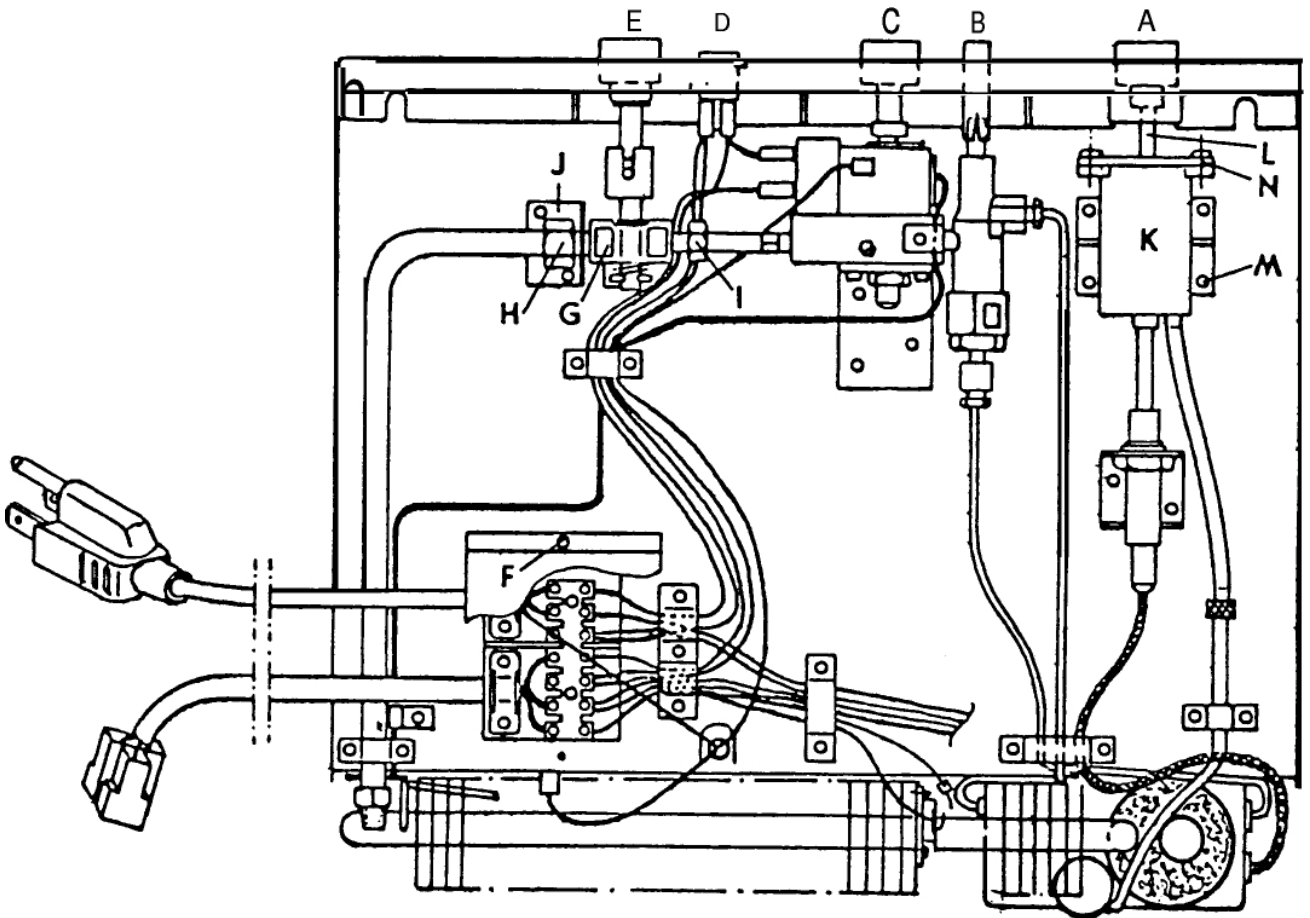

Fig.9

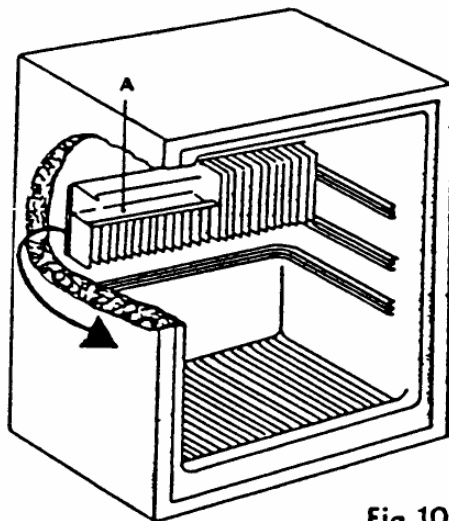

Fig.10

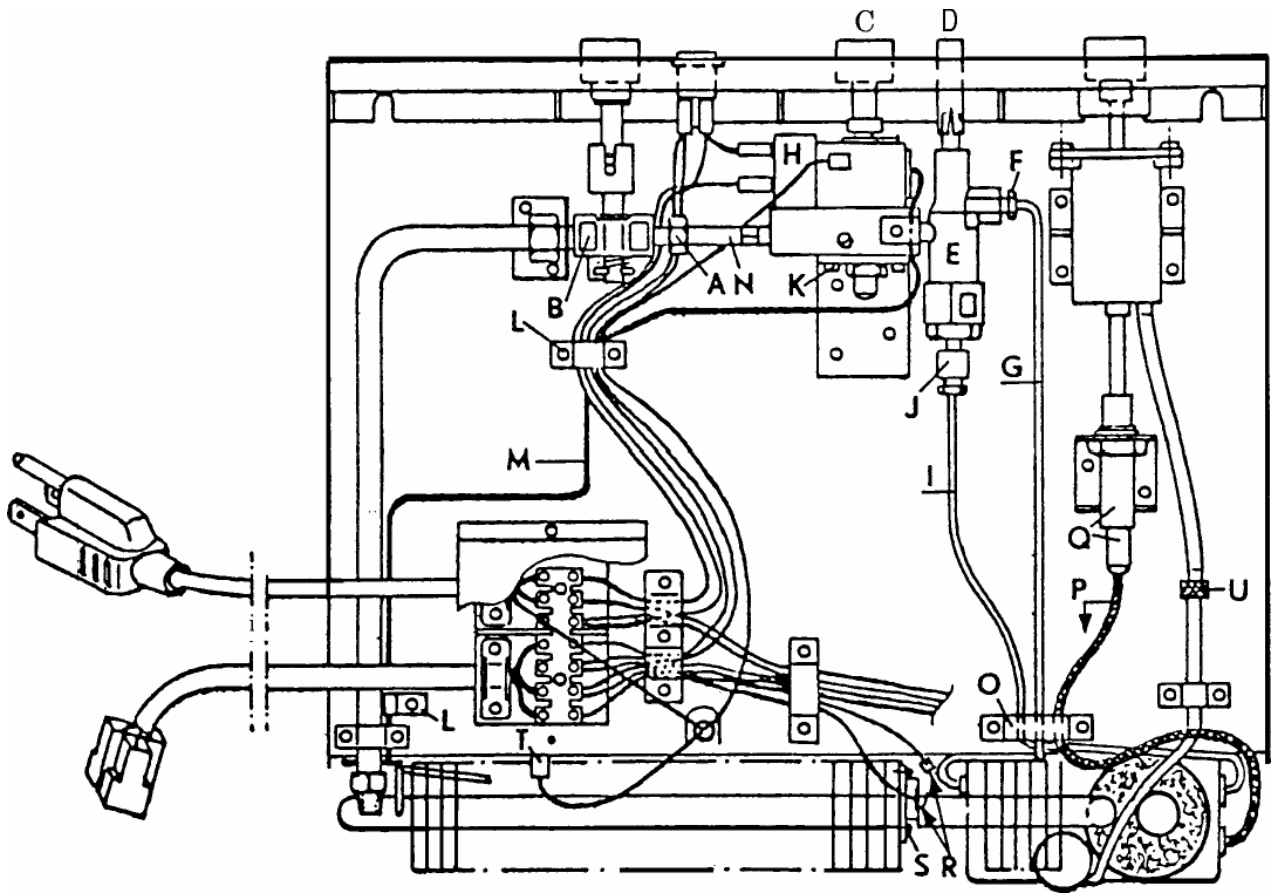

Fig.11

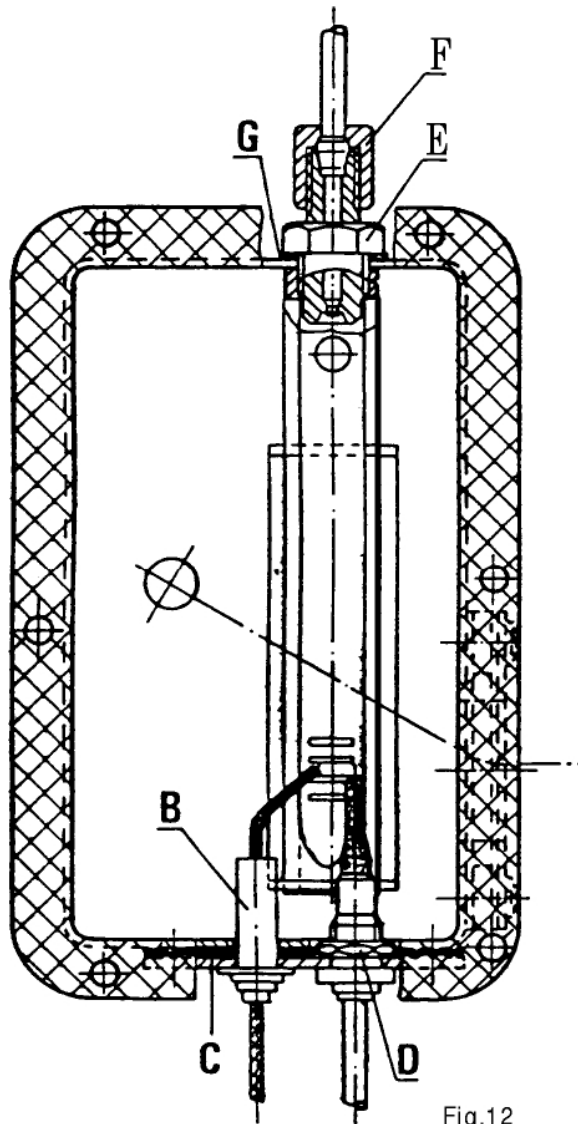
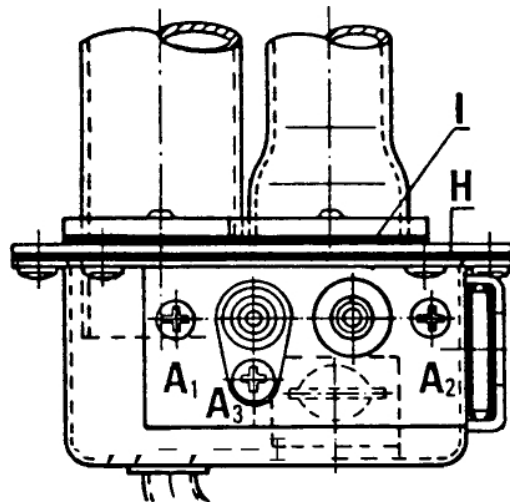

Fig.12

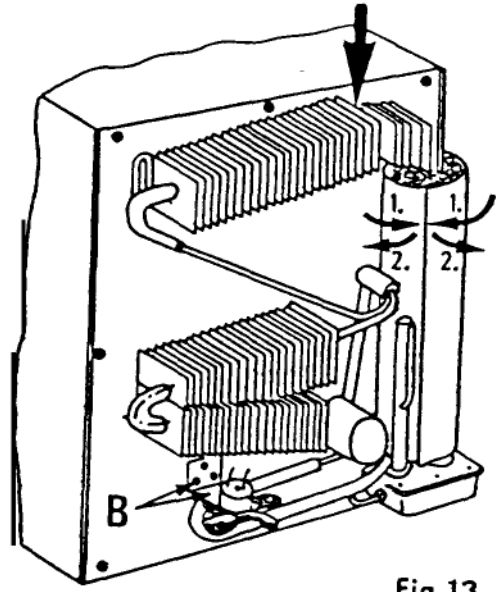

Fig.13

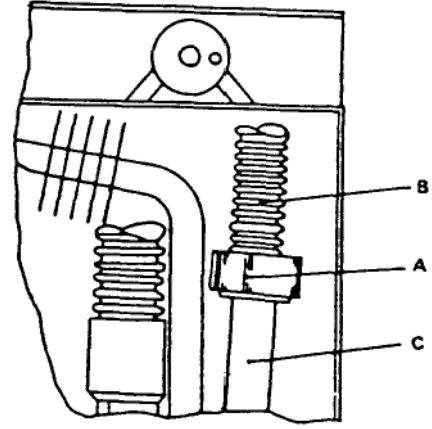

Fig.14

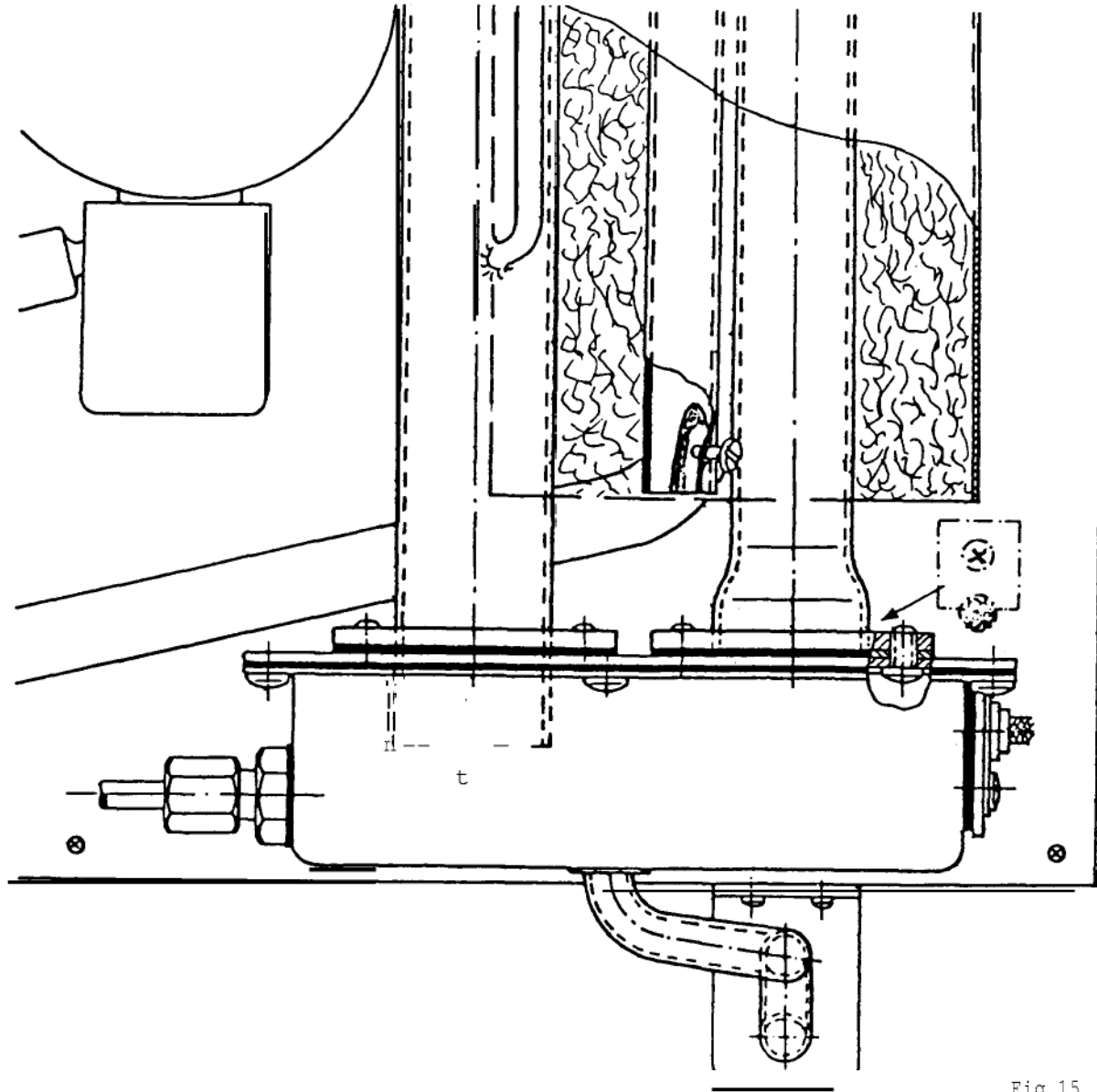

Fig.15